

FAST RESPONSE, TRANSIENT FREE REACTIVE POWER COMPENSATION SYSTEMS



EQUALIZER:

A real time transient free system, used to compensate extremely rapid loads within one cycle (typically 5-20 mSec).

ACTIVAR:

A fast transient free system, used to compensate any load within 3-4 seconds.

TYPES AVAILABLE:

- **Basic Systems:** Include iron core reactors to limit the inrush current.
- **Detuned Systems:** Include Iron core reactors that detune the network to prevent resonance and absorb up to 50% of the 5th harmonic
- **Tuned Systems:** Individually designed to absorb the 5th and 7th harmonics.

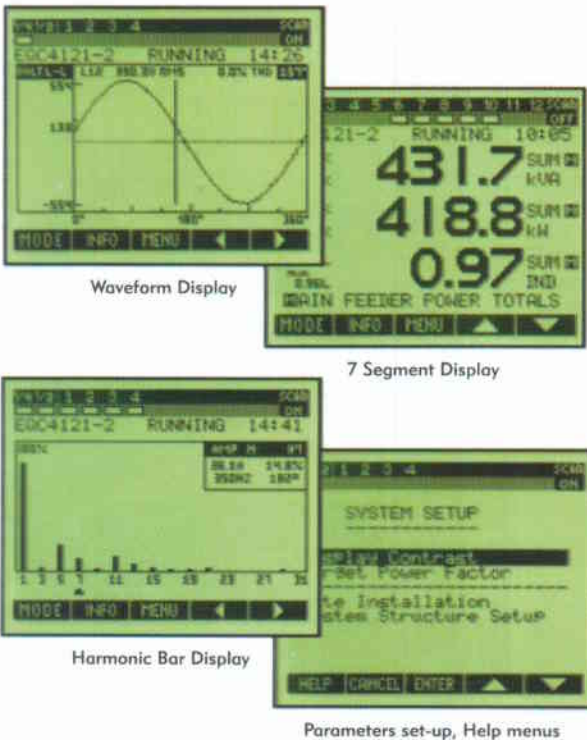

ADVANTAGES

EQUALIZER & ACTIVAR

- Transient Free capacitor group switching, using electronic switching elements
- Prevents damage to sensitive electronic equipment
- Saves energy
- Harmonic filtration
- Accurate power factor control, even in the presence of harmonics
- Dramatically increases the life expectancy of switching elements and capacitors
- Considerably lower temperature rise of capacitors and inductors due to unique scan feature
- Built-in three phase network analyzer, measuring all network parameters including harmonics
- Unique self testing and comprehensive reporting feature.

EQUALIZER (in addition to the above)

- Cycle by cycle reactive power compensation (total acquisition time of 5-20mSec)
- Prevents voltage drop and flickering
- Used for Real Time applications, such as spot welding and motor start-up
- Enhances capacity of local generator systems, such as diesel and windmill generators.



ACTIVAR

The ACTIVAR is a state of the art, electronic switching device designed to replace electromechanically switched equipment in power factor correction (PFC) systems.

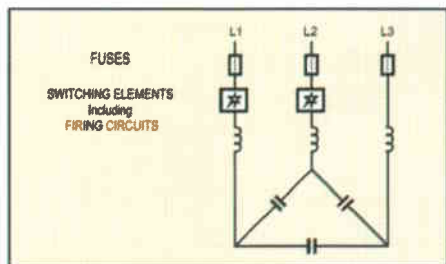

Smooth and transient free

Connection and disconnection of the capacitor to and from the network occurs at zero current crossing. This smooth connection avoids the transient effects typically created by electromechanically switched PFC systems. The total acquisition time (full compensation of reactive current) is only 3 to 4 seconds which is much faster than electromechanically switched PFC systems.

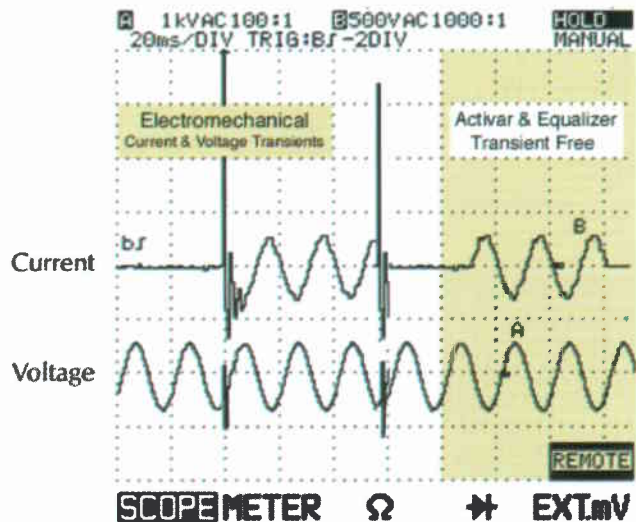

Longer Life

The electronic switches do not wear out or deteriorate during the switching process and the capacitors are not adversely affected by transients. These advantages contribute to a much longer life expectancy compared with electromechanically switched PFC systems.

POWER IQ Measurement & Analysis Software

This software displays the system's status as well as the measurement results on numerous screens running under Windows. All network parameters, including harmonics up to the 63rd can be recorded at preselected intervals. The duration of the recording is only limited to the size of the computer's hard disk. The software can be set to record data based on selected triggers of various network parameters, such as voltage sags and/or current spikes. The system records before and after the trigger event. The software has intranet and internet support.

Real Time Measurements

The power factor is controlled very accurately by means of an advanced closed loop control & measuring unit, that takes into consideration all three phases and the effect of harmonics (1 through 63).

Scan Mode

The ACTIVAR system is equipped with a unique scan feature that protects capacitors from "exploding" and contributes to longer life expectancy. This is achieved by reducing overcurrent and overheating in the capacitors which may result from harmonics on the mains. The switching element can perform an unlimited number of switching operations. The connection of one group of capacitors occurs simultaneously with the disconnection of another group. This operation is performed every few seconds and engages all capacitor groups in turn, resulting in a reduction of mean current due to the lower ratio of engagement time to cycle time (duty cycle.)

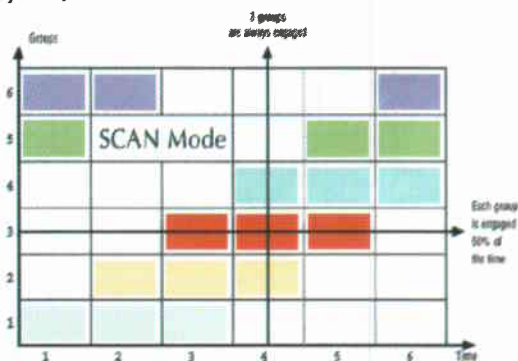

The scan feature, together with the unique reactor design, substantially reduces the temperature rise of the reactors and protects the cabinet from overheating.

Resonance Free

There is an ongoing, cumulative reduction of capacity in electromechanically switched PFC systems due to the effect of transients during connection and disconnection. This can be detrimental to detuned Electromechanically switched systems where the changes in ratio between the capacitors/reactors shift the resonance frequency, which may result in resonance. The ACTIVAR prevents these conditions.

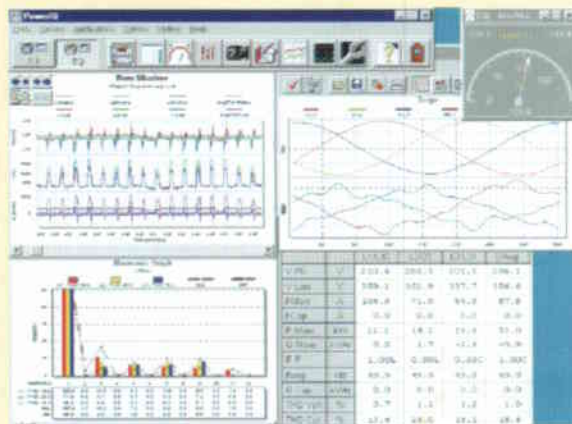

The EQUALIZER

The Equalizer is a fast response system that is used to compensate any variation in reactive power within one cycle of the network.

Correct compensation using the Equalizer

The top graph demonstrates how the Equalizer compensates the reactive current of fast loads with a duration of 14 cycles. Typical acquisition time (full compensation of reactive current) is less than one cycle and the total current is substantially reduced.

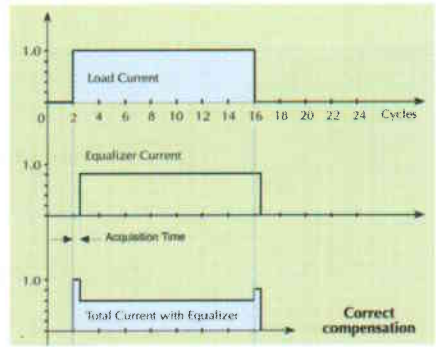

Adverse effects of slower response systems

The bottom graph demonstrates incorrect compensation where the response time is 3 cycles for the connection of a single group and the acquisition time required to connect a total of 4 groups is 12 cycles.

Due to the delay in compensation the current is partially reduced and due to the corresponding delay in disconnection of the capacitor groups there is residual current. The total effect of the compensation system on the current is negative since the average current of the load is increased instead of being reduced. This increases voltage flickering due to overcompensation.

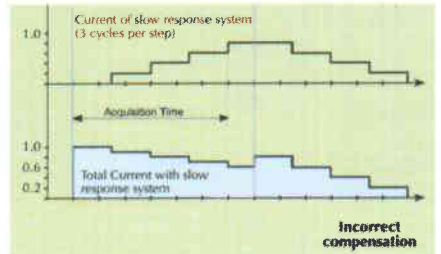

Applications

Large and rapid variations in reactive power normally occur during spot welding operations and motor start-up. The Equalizer minimizes the negative effects of these loads, resulting in improved power quality and system capacity.

Spot Welding

Spot Welding loads fluctuate extremely rapidly and consume large amounts of reactive power. Resultant voltage sags tend to reduce welding quality and can impact welding productivity. In addition, these loads often create a high level of voltage flickering, which frequently exceed the recommended IEEE limits.

High-Speed reactive compensation systems clearly offer the following benefits: Improved welding quality, increases process output and elimination of flickering. Significant capital investment is reduced by better utilization of the existing infrastructure.

The top and middle graphs demonstrate that the Equalizer prevents voltage drop and flickering; substantially reduces the current and compensates reactive energy.

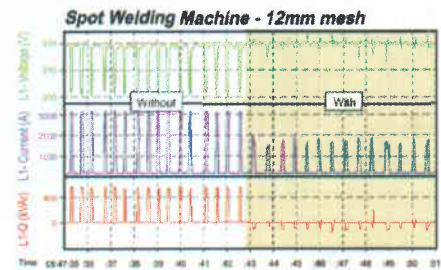
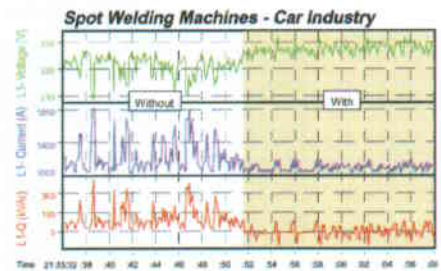

The bottom graphs demonstrate welder output current (car industry). The optimal condition is a stable current within a range of 11,000 amp. With the Equalizer, the current variations are +/- 200 Amp and without the Equalizer the current variations are +/- 800 Amp. A stable current significantly improves welding quality. Over-current can cause damage to the electrodes as well as to the material being welded. Undercurrent during welding operations deteriorates welding quality.



Central Compensation of Start-Up Current of Large Motors

Large squirrel case inductive motors, when connected directly on-line, consume high current during the start-up period (six times higher than steady state operation). However, if the network is weak, the high current leads to substantial voltage drops which interfere with other loads, reducing the initial torque and increasing start-up time.

The Equalizer tracks the reactive current, compensates it within one cycle, and provides the following features :

- Mains protection against voltage drops caused by high momentary consumption of reactive current
- Central starting of all loads, thus avoiding the use of individual starters required to protect the mains against voltage drop
- Direct connection of motor to mains, to obtain maximum torque during connection. This feature is unique to the Equalizer system, since starters of all types reduce the current going through the motor, thereby reducing the starting torque.

Voltage drop during motor start-up

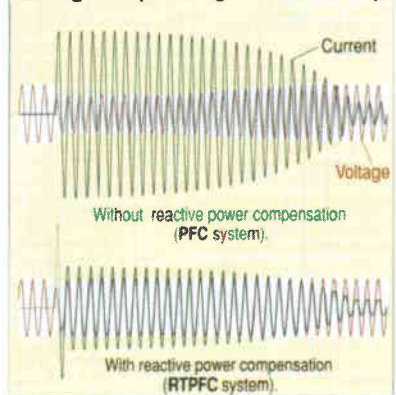

Functional Diagram

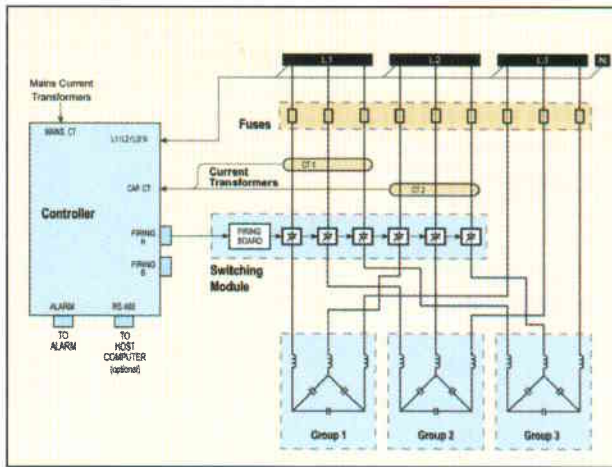

The CONTROLLER

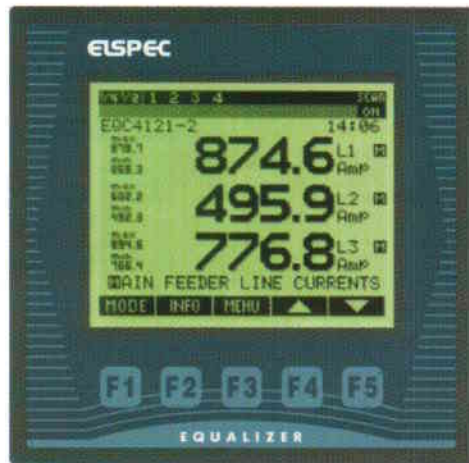

Standard systems Without Circuit Breaker

- Single cabinet 80x60x210 cm (W x D x H), 3 groups
- Dual door single cabinet 100x60x210 cm, 4 groups
- Two cabinets 160x60x210 cm, 9 groups
- Four cabinets 120x60x210 cm, 12 groups

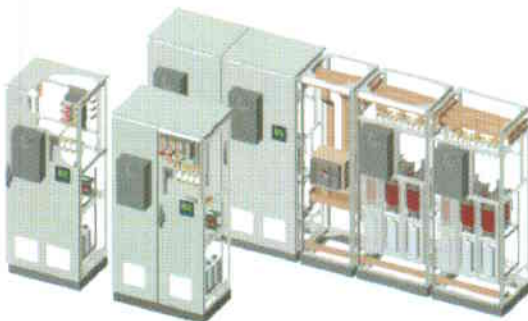

NEEL INDUSTRIAL SYSTEMS PVT. LTD.

402, Sapphire Arcade, 42, M.G.Road, Ghatkopar (East),
 Mumbai - 400 077.
 Tel : 022-2516 4326/27
 Fax : 022-2516 4317
 Email : neelsys@vsnl.com, neelsys@dishnetdsl.net
 Website : www.neelsystems.com



Measurement

Parameter	Phases	Loads	Measurement Level			
			1	2	3	4
Frequency	Common	Mains	●	●	●	●
Phase Current	L1, L2, L3	Mains, Load, Cap	●	●	●	●
Neutral Current	Neutral	Mains	●	●	●	●
Phase to Phase Current*	L1-2, L2-3, L3-4	Mains, Load	●	●	●	●
Phase Voltage	L1, L2, L3	Mains	●	●	●	●
Neutral Voltage	Neutral	Mains	●	●	●	●
Phase to Phase Voltage	L1-2, L2-3, L3-4	Mains	●	●	●	●
Active Power (kW)	L1, L2, L3 Total	Mains	●	●	●	●
Reactive Power (kVar)	L1, L2, L3 Total	Mains, Load, Cap	●	●	●	●
Apparent Power (kVA)	L1, L2, L3 Total	Mains, Load, Cap	●	●	●	●
Power Factor	L1, L2, L3 Total	Mains, Load, Cap	●	●	●	●
Time of use (TOU), In, out, net, total			●	●	●	●
Active Energy (KWh)	Total	Mains	●	●	●	●
Reactive Energy (kVARh)	Total	Mains	●	●	●	●
THD at Phase Current	L1, L2, L3	Mains, Load, Cap	●	●	●	●
THD at Neutral Current	Neutral	Mains	●	●	●	●
THD at Phase to Phase Current	L1-2, L2-3, L3-1	Mains, Load	●	●	●	●
THD at Phase Voltage	L1, L2, L3	Mains	●	●	●	●
THD at Neutral Voltage	Neutral	Mains	●	●	●	●
THD at Phase to Phase Voltage	L1-2, L2-3, L3-1	Mains	●	●	●	●
Harmonics of Phase Current	L1, L2, L3	Mains, Load, Cap	●	●	●	●
Harmonics of Neutral Current	Neutral	Mains	●	●	●	●
Harmonics of Phase to Phase Current	L1-2, L2-3, L3-1	Mains, Load	●	●	●	●
Harmonics at Phase Voltage	L1, L2, L3	Mains	●	●	●	●
Harmonics at Neutral Voltage	Neutral	Mains	●	●	●	●
Harmonics at Phase to Phase Voltage	L1-2, L2-3, L3-1	Mains	●	●	●	●
Waveforms of Phase Current	L1, L2, L3	Mains, Load, Cap	●	●	●	●
Waveforms of Neutral Current	Neutral	Mains	●	●	●	●
Waveforms of Phase to Phase Current	L1-2, L2-3, L3-1	Mains, Load	●	●	●	●
Waveforms at Phase Voltage	L1, L2, L3	Mains	●	●	●	●
Waveforms at Neutral Voltage	Neutral	Mains	●	●	●	●
Waveforms at Phase to Phase Voltage	L1-2, L2-3, L3-1	Mains	●	●	●	●
System Log			●	●	●	●
Event Log			●	●	●	●
Data Log (future)			●	●	●	●

* Unique features metering internal current of feeder transformer/delta secondary

CAPACITOR/REACTOR MODULE

The Equalizer includes custom designed, iron core reactors in series with the capacitors.

Iron Core Reactors

The iron core reactors are manufactured under tight tolerances. The reactors are constructed with a laminated low hysteresis losses iron core, precision controlled air gaps and copper windings, and have class H insulation (180°C).

Systems without tuned or detuned reactors are equipped with limiting reactors designed to limit the inrush current which may develop in the capacitors during power up. This avoids damage to the switching elements, fuses and capacitors.

The detuned reactors prevent resonance by shifting the capacitor/network resonance frequency below the first dominant harmonic (usually the 5th).

A tuned reactor design is available upon request (to absorb most of the 5th and 7th harmonics.)

Capacitors

The capacitors are low loss (0.25W/kVar) MKP type in cylindrical aluminium casing. The MKP capacitor is a metallized polypropylene film capacitor with self healing properties and an overpressure tear-off fuse.

Capacitor elements for 400V and 480V networks are rated 440V+10% and 525V+10% respectively to cope with harmonics and over voltage. The capacitors are connected during current zero crossing, and operated in time sharing (SCAN mode), in order to reduce the effects of electrical or thermal overload and ensure an extended period of operating time (statistical life expectancy : over ten years).

SWITCHING MODULE

The switching module is comprised of solid state switching elements, which provide reliable, high speed, transient free operation. Each switching module switches upto three capacitor groups, using double phase electronic switches for each three phase capacitor group.

- Bangalore
- Chennai
- Delhi
- Indore
- Jalandhar
- Jamshedpur
- Kanpur
- Kolkatta
- Pune
- Rajkot
- Secunderabad
- Surat

Under Technical Collaboration with ELSPEC Engineering Ltd - Israel